

LOS SETUP SHEET EIGHT

Name: MICHAEL TODD
 City: _____ State: _____

Date: 3/8/08 Event: SAOMCC R07
 Track: AGHALEE

Track Indoor Tight Smooth Hard Packed Blue Groove Wet Low Bite High Bite
 Conditions Outdoor Open Rough Loose/Loamy Dry Dusty Med Bite Other _____

Front Suspension

Toe: 0°
 Ride Height: DRIVESHAFTS LEVEL
 Camber: -1°
 Caster: 20°
 Sway Bar: 2.32MM
 Piston/Oil: 35W 1555555
 Spring: SILVER
 Limiter/Droop: _____
 Overall Shock Length: _____
 Steering Ackerman: LONG
 Bump Steer: DOWN
 Camber Link: 3
 Shock Location: 2 | INSIDE
 Front Diff Fluid: 5000W
 Receiver Battery Type: 1600MAH
 Center Diff Fluid: 7000W

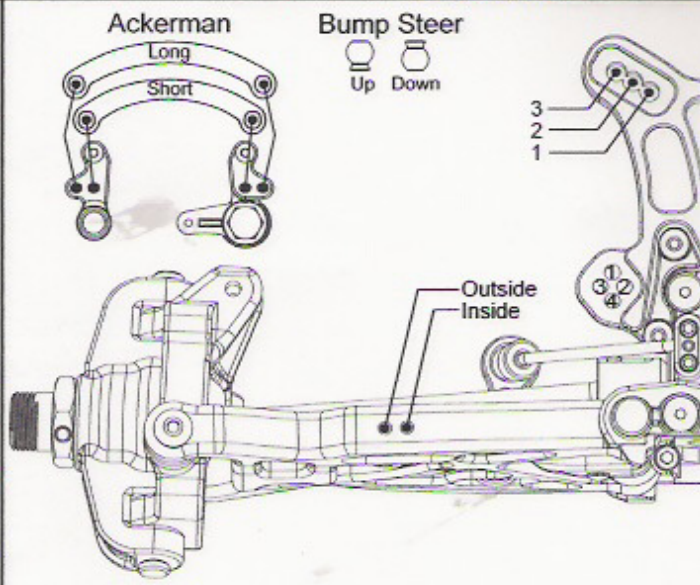

Notes: KICK UP +1°

Rear Suspension

Toe: 3°
 Anti-Squat: 2°
 Ride Height: DRIVESHAFTS LEVEL
 Camber: -2°
 Rear Hub Spacing: 2 SPACERS IN FRONT, 1 BEHIND
 Sway Bar: 2.2MM
 Piston/Oil: 30W 1666555
 Spring: SILVER
 Limiter/Droop: _____
 Overall Shock Length: _____
 Camber Link: 5-B
 Shock Location: 2 | INSIDE
 Rear Diff Fluid: 3000W

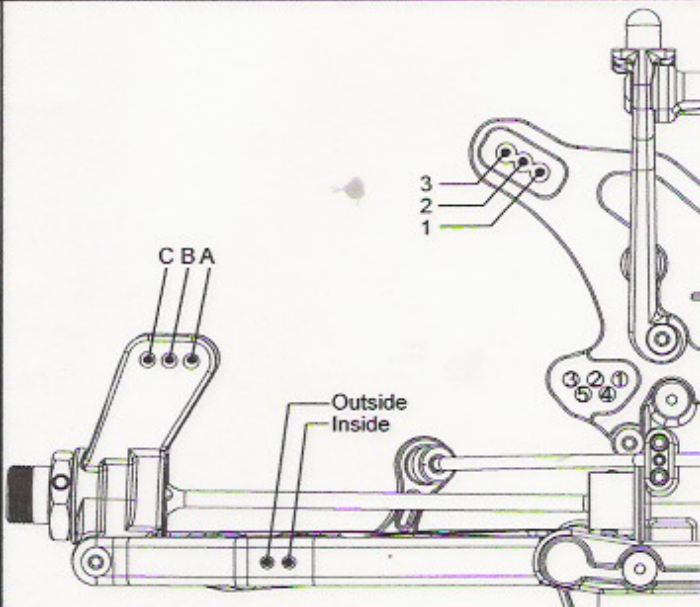

Notes: _____

Engine

Engine: NOVAROSS 367 Fuel: BYRON GEN2 25%
 Glow Plug: NOVAROSS 66 Head Clearance: _____
 Pipe/Header: NOVAROSS 9901 Gearing: 14/48

Clutch



Clutch Shoes and Springs Info
4 ALUMINIUM SHOES -
SILVER SPRINGS
MOUNTED NORMALLY

Tires

	Type	Compound	Insert
Front:	<u>LOSI STEP PIN</u>	<u>SILVER</u>	<u>STANDARD</u>
Rear:	<u>LOSI STEP PIN</u>	<u>SILVER</u>	<u>STANDARD</u>
Notes:	_____		